



Матка модрини с ЦТБ и КЗМ - Београд
Матка модрини с ЦТБ и КЗМ - Београд
Матка модрини с ЦТБ и КЗМ - Београд
Матка модрини с ЦТБ и КЗМ - Београд
Матка модрини с ЦТБ и КЗМ - Београд



GAS FIRE-FIGHTING UNITS

"ZARYA" CLEAN AGENT FIRE SUPPRESSION SYSTEM UNITS 3/10/22

with solenoid valve



Data sheet and operation manual ver. 019

Unit serial number

**ATTACHMENT A
(referential)**

**RUSSIAN FEDERATION
CERTIFICATE OF CONFORMITY
(mandatory certification)**

№ C-RU.11B97.B.00198
(certificate of conformity number)

TR 1389895
(the form tracking number)

APPLICANT "Innovative Fire Safety Systems" Limited Liability Company. Address: Moscow, 109202.
(name and location of the applicant) 5/1 Frezer highway. Manufacture address: Russia, 445043, Togliatti, Samara Region. 121 Yuzhnoe Shosse. PSRN (Primary State Registration Number): 1137746185345. Telephone: 88005550873. fax: 88005550873. E-mail: office@brigada01.ru.

MANUFACTURER "Innovative Fire Safety Systems" Limited Liability Company. Address: Moscow, 109202.
(name and location of the product manufacturer) 5/1 Frezer highway. Manufacture address: 445043. 121 Yuzhnoye Shosse, Togliatti, Samara region. PSRN (Primary State Registration Number): 1137746185345. Telephone: 88005550873. fax: 88005550873. E-mail:office@brigada01.ru

CERTIFICATION BODY

(name and location of certification body, which issued the certificate of conformity)

FSBEI (Federal State Budgetary Educational Institution) of Higher Professional Education Academy of State fire-fighting Service of the Ministry of Emergency Situations of Russia. Address: 4, Boris Galushkin Str., Moscow, 129366. Telephone: +7 (495) 617-29-33. Fax: +7 (495) 617-27- 29, E-mail: agps-oc@mail.ru, PSRN 1027739451684.

reg. No. RA.RU.11B97, dated 01.07.2015 The Federal Service for Accreditation.

CONFIRMS THAT PRODUCTS

(information about certification object allowing to identify the object)

Gas fire-fighting units with electrical, pneumatic and / or mechanical launch of ZARYA type with operating pressure of 1.6 MPa.

(information about certification object , with cylinders with a capacity 3.0 l, 10 l and 22.5 l, with diameter of lock and release device nominal width of 18 mm of models ZARYA-3 (ILLEGIBLE 18), ZARYA-10 (1.6-10-18) ZARYA-22 (1.6-22.5-18); manufactured in accordance with TS 4854-001-62437227-2015. Serial production.

All-Russian Classifier code 005 (All-Russian Product Classifier) 48 5487

MEETS THE REQUIREMENTS OF TECHNICAL REGULATIONS (TECHNICAL REGULATIONS)

(name of technical regulations (technical regulations) for conformance to the requirements of which the certification was carried out)

Technical regulations for fire safety requirements (Federal law dated 22.07.2008 No. 123-FZ). GOST 53281-2009 "Automatic gas fire extinguishing systems. Cylinders and cylinder banks. General technical requirements. Test methods".

UCIA (Universal Codifier of Issue Article) code

Russian Commodity Nomenclature of Foreign Economic Activity (CN of FEA) code 8424 90 000 0

UNDERTAKEN STUDIES (TESTS) AND MEASUREMENTS

Act on analysis results of certified products state of production No. 2471 TR-2015 dated 18.11.2015.

(Certification Body Academy of State fire-fighting Service of the Ministry of Emergency Situations of Russia, reg. no. RA.RU.11B97 dated 01.07.2015). Certification Test Report No. 174-2015 dated 09.12.2015 (TL Certification Test Laboratory of fire extinguishing equipment of Academy of State fire-fighting Service of the Ministry of Emergency Situations of Russia No. RA.RU.21HX15 dated 16.04.2015); certification scheme: 4 p.

SUBMITTED DOCUMENTS

(documents submitted by the applicant to the certification body as the proof of products conformity to the requirements of the technical regulations (technical regulations))

TS 4854-001-62437227-2015; CU Declaration N RU D-RU.AG95.B.00641 dated 14.12.2015 of conformity to the requirements of TR CU 032 2013 "On safety of equipment operating under excessive pressure".

CERTIFICATE OF CONFORMITY TERM OF VALIDITY is from 17.12.2015 **till** 16.12.2020

Head of (deputy head) of certification body

Signature, initials, surname

/signature/

M. V. Aleshkov

Seal here

(stamp: Academy of State fire-fighting Service of the Ministry of Emergency Situations of Russia Certification Body RA.RU.11B97 TR)

Expert member (expert members)

signature, initials, surname

/signature/

I. F. Zhitenko

CONTENTS

1	PRODUCT DESIGNATION	3
2	TECHNICAL CHARACTERISTICS	4
3	SCOPE OF SUPPLY	6
4	PRODUCT COMPOSITION AND PRINCIPLE OF OPERATION	6
5	CONNECTION DIAGRAMS OF THE UNIT'S ELECTRIC CIRCUITS	9
6	SAFETY PRECAUTIONS	10
7	UNIT PREPARATION FOR OPERATION	11
8	MAINTENANCE	13
9	TRANSPORTATION AND STORAGE	16
10	DISPOSAL	18
11	TEST CERTIFICATE	19
12	Warranty liabilities. LIFETIME GUARANTEE	20
13	INFORMATION ABOUT THE CONTAINER	21
	Attachment A (referential) Certificate of Conformity of RF	1
	Attachment B (obligatory) Complex of taken measures	24
	Attachment C (referential) Temperature-pressure dependency diagram	25
	Attachment D (obligatory) Data on unit activation	26
	Attachment E (obligatory) Data on technical expert examination	27

The present operation manual combined with data sheet for gas fire-fighting units "ZARYA", TS 4854-001-62437227-2015 (hereinafter referred to as the "unit"), contains the device description and units principle of operation, technical characteristics guaranteed by the Manufacturer, instructions for correct units operation.

Upon studying of the units components and their operation one should be guided by "TR CU 032/2013. Technical Regulations of the Customs Union. On safety of equipment operating under excessive pressure" and the present Manual.

The units are produced under TS 4854-001-62437227-2015 and conform to GOST R 53281—2009.

The units are certified by Academy of State fire-fighting Service of the Ministry of Emergency Situations of RUSSIA in accordance with the procedure of mandatory certification.

Certificate of conformity C-RU.ПЕ97.В.00198 is valid from 17.12.2015 to 16.12.2020 (attachment A).

Gas fire-fighting units designing on "ZARYA" clean agent fire suppression system units should be carried out in accordance with set of rules "Systems of fire protection. Automatic fire-extinguishing and alarm systems. Designing and regulations rules" SP 5.13130.2009

The logo for ZARYA, featuring the word "ZARYA" in a bold, sans-serif font inside a dark, rounded rectangular shape.

1 PRODUCT DESIGNATION

The unit is intended for fire-fighting by means of gas fire extinguishing agent (clean agent) of fires of classes A, B, C and electrical equipment under voltage of up to 10 000 V.

The unit is intended for use as part of automatic fire-fighting units and as self-contained fire extinguishing equipment.

For signalling about activation (failure), the unit is equipped with an electric contact pressure gauge.

The unit is not intended for use in explosion-prone areas

The unit corresponds to the climatic version UHL 3 according to GOST 15150, within the temperature range from - 10°C to + 50°C.

The unit corresponds to the climatic version UHL 3 according to GOST 15150, within the temperature range from - 10°C to + 50°C.

Protection degree provided by electrical parts enclosure of the unit is IP 54 according to GOST 14254-2015.

2 TECHNICAL CHARACTERISTICS

2.1 Types of launch

● **Automatic launch:** takes place at electrical starting impulse input to solenoid valve coil during activation of general fire-fighting system sensor.

● **Manual launch:** takes place at electrical starting impulse input to solenoid valve coil by pressing an alarm button of manual launch.

2.2 Parameters of electric contact pressure gauge electrical circuit

- | | |
|---------------------------------|-------------------|
| ● Direct current voltage, V | from 4,5 to 24 |
| ● Electric current intensity, A | from 0,005 to 0,1 |
| ● Maximum capacity, W | 2.4 |

2.3 Parameters of the unit electrical launch

Solenoid valve of normally closed type.

- | | |
|--|----|
| ● Direct current voltage at coil contacts, V | 24 |
| ● Power, W | 12 |

2.4 Unit characteristics

Unit technical characteristics are in accordance with the **Table 1**.

Maximum operating pressure (at ambient temperature of 50 °C), maximum 3 MPa (30 kgf/cm²).

Name, chemical formula of clean agents used in the unit, are in accordance with the **Table 2**.

Service life of the unit is 10 years.

The unit service life until a successive expert examination is five years.

Table 1 - Unit technical characteristics

Clean agent fire suppression system unit name		ZARYA-3	ZARYA-10	ZARYA-22
Parameter name				
Container capacity, l		3±0,15	10±0,5	22,5±1,1
Operating pressure at ambient temperature 20±2°C, MPa (kgf/cm ²)		1,6 (16)		
Minimum operating pressure, MPa (kgf/cm ²)		1,0 (10)		
Test pressure, MPa (kgf/cm ²)		5,5 (55)		
Diameter of the lock and release device nominal width, mm		18		
Response time of activation (time from the moment of starting impulse input to the beginning of clean agent outlet), with maximum		2		
Duration of clean agent release at ambient temperature 20±2°C, with maximum		10		
Bursting pressure of pressure safety element, MPa (kgf/cm ²)		5,0±0,5 (50±5)		
Clean agent remainder after release		without remainder		
Equivalent length of the unit, m, maximum		0.7		
Maximum filling of units with clean agent, kg	HFC 227ea	3	11	24
	FK-5-1-12	3.5	12	27
Unit launch method		automatic / manual		
Overall dimensions, mm, maximum	diameter	210	310	360
	height	350	395	545
Weight (without clean agent) kg, maximum		7.0	10.3	13.6
Life-span of activation, times, minimum		10		

Table 2 - Characteristics of applied clean agents

Product name of clean agent	Chemical name (formula) of clean agent	Symbolic designation
HFC 227ea	Heptafluoropropane (C ₃ F ₇ H)	HFC-227ea
FK-5-1-12	Perfluoro (ethyl-isopropyl ketone) CF ₃ CF ₂ C(O)CF(CF ₃) ₂	FK-5-1-12

3 SCOPE OF SUPPLY

The scope of supply includes:

- a unit assembled, in accordance with the specification;
- Clean agent (type of fire-extinguishing agent is specified at order);
- a sprayer;
- high-pressure hose (availability and length are specified at order);
- a fixture (wall bracket and / or ceiling bracket);
- data sheet and operation manual for the unit;
- packing.

4 PRODUCT COMPOSITION AND PRINCIPLE OF OPERATION

Gas fire-fighting unit "ZARYA" (**Drawing 1**) consists of a container 1, filled with liquefied clean agent with propellant gas, and a lock and release device 4.

The container is fixed to the bracket 3 with the help of a pad 2. The lock and release device 4 is installed into the container connection.

A solenoid valve normally closed **5**; an electric contact pressure gauge **6**; a safety device **7**; a sprayer **8** and a grounding terminal **9** are built into the lock and release device (**drawing 2**). A solenoid valve **5** must be connected to the fire fighting control device.

A safety device **7** serves for excessive pressure outlet from the unit upon reaching of critical values ($5,0 \pm 0,5$) MPa. After excessive pressure outlet a safety device **7** is subject to replacement, and the unit is subject to filling with clean agent.

For the prevention of possible clean agent leakages during transportation, storage, installation and maintenance, a "safety screw" **10** is installed instead of a sprayer.

Remove a "safety screw" **10** and install a sprayer **8** upon the unit positioning into alert mode.

An electric contact pressure gauge **6** is intended for visual pressure control in the unit and signalling about activation (failure) of the unit in the process of operation.

Contact wires of the pressure gauge should be coupled to fire alarm control panel. At pressure drop in the unit container **below 0,6 MPa**, contact closing takes place. With that, on-off signal about activation or the unit unsealing is formed.

Limit of permissible reference error of pressure gauge should not exceed $\pm 10\%$ within working range, and in the rest of the range $\pm 15\%$ from upper-range value.

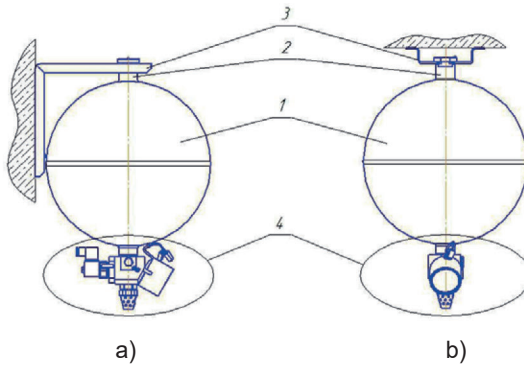

1 - high-pressure container; 2 - pad;
 3 - bracket; 4 - lock and release device assembled.
 a - fixture variant on the wall; b - fixture variant on the ceiling

Drawing 1 - "ZARYA" Unit

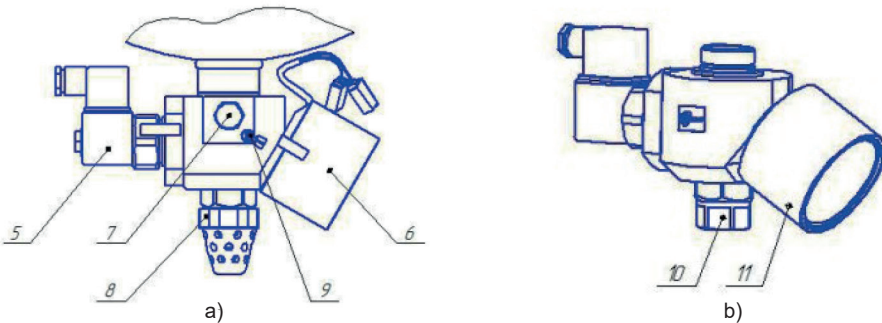

5 - solenoid valve; 6 - electric contact pressure gauge; 7 - safety device;
 8 - sprayer; 9 - grounding terminal; 10 - "safety screw"; 11 - protective collar
 a) a lock and release device with a sprayer; b) a lock and release device with a "safety screw"

Drawing 2 - Lock and release device

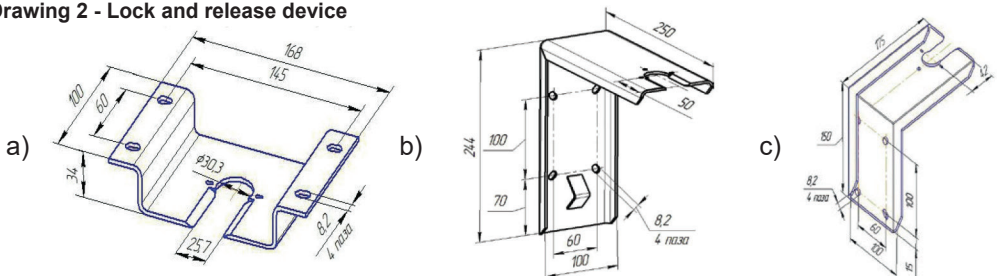

Drawing 3 - A bracket for the unit fixture: a - ceiling for "ZARYA-3/10/22" Clean agent fire suppression system units;
 b - wall for "ZARYA-10/22" Clean agent fire suppression system units; c - wall for "ZARYA-3" Clean agent fire suppression system unit

ZARYA

At the request of the Client "ZARYA" gas fire-fighting unit with a solenoid valve is additionally completed with high pressure hose (**drawing 4**). Availability and length of a solenoid valve are specified at order. Solenoid valve length is maximum three meters.

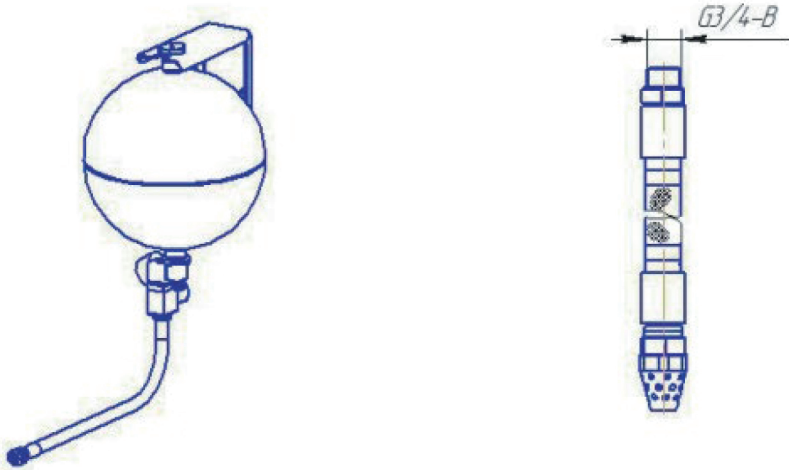

Drawing 4 - Unit with high pressure hose

Unit principle of operation

After signal arrival from the fire alarm to the fire alarm control panel, the latter forms an instruction for a unit (units) activation and the fire fighting control device sends electrical impulse for a solenoid valve activation. The valve opens, clean agent under pressure in the unit's container is discharged into the protected area through a sprayer / a solenoid valve.

At pressure drop in the container **below 0,6 MPa**, the signal about the unit **activation or unsealing** is coming from the electric contact pressure gauge to the fire alarm control panel.

5 CONNECTION DIAGRAMS OF THE UNIT'S ELECTRIC CIRCUITS

5.1 Electric contact pressure gauge

An electric contact pressure gauge is used for signalling about activation (failure) of the unit to the fire-fighting control panel.

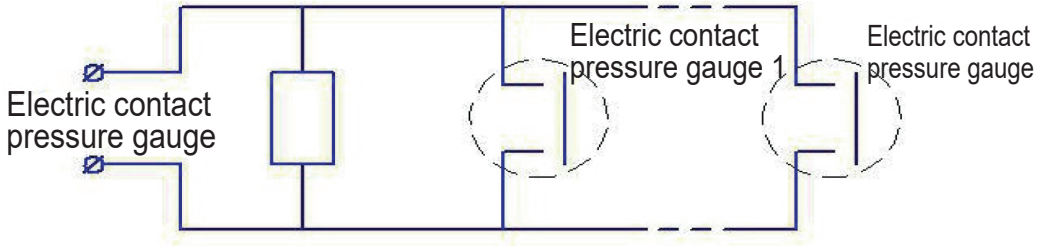

Drawing 5 - Electric contact pressure gauge connection diagram

5.2 Solenoid valve

Important! Solenoid valve of normally closed type.

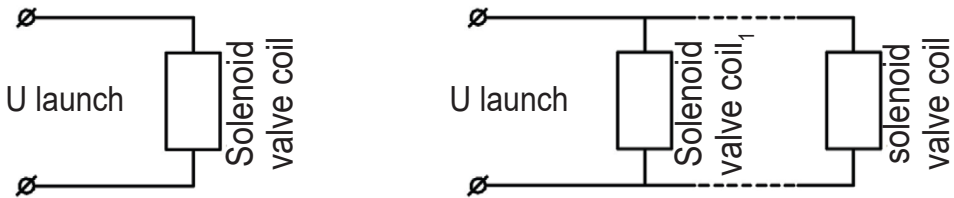

Drawing 6 - EMA connection diagram: a) one unit; b) several units.

5.3

In case of automatic fire-fighting units development based on several units, it is necessary to provide their simultaneous launch. For these reasons, solenoid valves must be connected according to the diagram presented **in the drawing 6b**, with that, it's necessary to take into consideration technical characteristics of automatic fire extinguishing system control devices.

6 SAFETY PRECAUTIONS

6.1

The unit's maintenance must be carried out by two persons, having studied the device and principle of its operation, who have undergone industrial training and are certified to operate containers working under pressure.

6.2

Works connected with the unit disassembly and assembly, must be carried out at a total absence of pressure and at switched-off electric power supply.

6.3

A unit location near heating units is not allowed. The distance from the unit nozzle to any barriers (cabinet units, partitions, bridging, etc.) must be minimum 1 m.

6.4

Unit falling or impacts on it are not allowed.

6.5

Operation of the unit is not allowed if the container's successive expert examination term has expired, and also if defects excluding guarantee of the units safe operation have been revealed.

6.6

The unit installation, removal and transportation at absence of the "safety screw" **10(Drawing 2 b)** are not allowed.

6.7

It is necessary to carry out the unit installation directly at its operation place. **It is allowed to relocate the unit only in individual package.**

6.8

High-pressure hose included into the unit should be safely secured at the object from possible movement of high-pressure hose at the unit activation.

IMPORTANT! When identifying **COUNTERFEIT** products, contact the manufacturer without delay by the 24-hour hotline 8 (800) 500-30-26

7 UNIT PREPARATION FOR OPERATION

7.1

Keep the unit at a constant temperature (within the range of operating temperatures) during not less than 10 hours.

7.2

At unit preparation for installation it is necessary to:

- unpack the unit;
- check the unit's completeness;
- check pressure in the unit;
- check the unit total weight according to the data sheet data (see Section 11).

IMPORTANT! When identifying any nonconformity in technical characteristics, data sheet specifications completeness, appearance, it is necessary to contact the manufacturer without delay for corrective action. Claims in relation to completeness, presence of mechanical damages, appearance of the unit are not admitted upon the expiration of 14 days from the date of acceptance by the Buyer.

7.3

The unit installation should be carried out in accordance with fire-fighting system project to the walls or the ceiling with the help of a bracket (**drawing 3**). The unit's fixture and components of the structure, on which the unit is installed, must withstand static load of minimum 600 N and impulse dynamic load of minimum 1000 N. The bracket is installed on a flat tested surface with the help of anchor bolts. The unit's pad **1** is inserted into the bracket groove **2** against the stop, after which it is necessary to rotate the unit by 90 degrees until clicking position of fixing mechanism coupling rod **3**, installed in the unit pad (**drawing 7**).

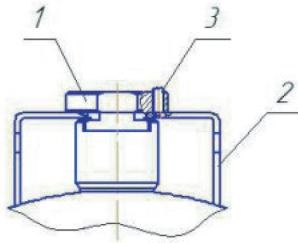

1 - pad; 2 - bracket; 3 - fixing mechanism

Drawing 7 - Unit installation

7.4

After the unit installation the electric circuits of a solenoid valve and an electric contact pressure gauge are connected to the fire alarm control panel. **The unit must be grounded by all means.**

7.5

After the unit installation at the object, before its positioning into alert mode, **remove a “safety screw” 10 (Drawing 2b)** and install a sprayer **8 (drawing 2a)**. If the unit is supplied with a high pressure hose, then after the unit installation at the object, before its positioning into alert mode, remove a “safety screw” **10 (drawing 2b)** and install a high pressure hose in accordance with the **drawing 4**. Safely secure high-pressure hose from possible movement at the unit activation.

7.6

During installation in order to avoid the unit unsealing, it is prohibited to set hands to the lock and release device and the pressure gauge.

7.7

Installation and maintenance of the units must be carried out by persons licensed to execute such works.

7.8

It is forbidden to install the unit in places where it can have mechanical impact (vibration, impulses, impacts, heavy objects falling), near heating units, in places where direct exposure to sunlight is possible.

8 MAINTENANCE

8.1 Maintenance during operation

In the process of the unit operation it is necessary to carry out scheduled maintenance fulfilled by trained personnel according to the Regulations 1, 2, 3, and 4. Carry out works in personal protective equipment.

Before the beginning of works on maintenance it is necessary to remove a sprayer 8 (disconnect high pressure hose, if available) from the unit lock and release device and **install a "safety screw" 10 (drawing 2)**.

For works carrying out according to Regulations 2, 3, and 4 it is necessary to perform **preparatory works**: switch off electric power supply of the unit, disconnect contacts of electronic components, remove the unit from the fixture (press down locking ball **3 (drawing 7)** and rotating the unit by 90 degrees, withdraw it from a bracket groove) and install into steady position with the lock and release device upwards.

Regulation No. 1. Once every three months:

- clean from dust, industrial pollution;
- control pressure in the unit container. Control pressure by an electric contact pressure gauge of the lock and release device. Enter the value into the log;
- **at pressure drop in the unit below 1,0 MPa, notify the manufacturer or service organization without delay for corrective action;**
- make visual inspection of the unit, check integrity of parts and units;
- at coatings disturbance, clean the defective areas from corrosion and other contaminating impurities and lubricate with anticorrosive grease.

Regulation No. 2. Annually:

- carry out operations according to regulation No. 1;
- perform preparatory works (see above);
- carry out examination of clean agent integrity by means of the unit weighting. In case of clean agent weight reduction in the unit container by more than 5% from filled one (according to data sheet), the unit is subject to refuelling or refilling at the nearest service centre of the manufacturer or the specialized organization;
- install the unit into the fixture;
- connect contacts of an electric contact pressure gauge and a solenoid valve;
- connect the unit to electric power supply;
- **before the unit positioning into alert mode, remove a "safety screw" 10 and install a sprayer 8 (drawing 2).**

Enter information on refuelling or refilling into the Table B. 1 (attachment B).

Regulation No. 3. Two years after the date of verification of the electric contact pressure gauge (according to the verification stamp at the pressure gauge) and then every two years:

- carry out operations according to regulation No. 2;
- perform preparatory works (see above);
- remove a protective collar **11 (drawing 2 b)**;
- unscrew the electric contact pressure gauge with the help of a wrench (S=14) holding the connection of the lock and release device with the help of a wrench (S=14). Upon unscrewing, fizzle and possibly quiet click will be heard. If fizzing doesn't terminate, it is necessary to screw in the pressure gauge to its place (in case of the unit contents release be careful of penetration on clothing and skin, long-term exposure can cause frostbite). Inform the manufacturer about failures;
- after fizzing termination, unscrew the pressure gauge, remove copper sealing ring installed in the connection under the pressure gauge;
- **carry out pressure gauge verification at the specialized organization** (an organization being entitled to carry out metrological works, for example, Federal Center for Standardization and Metrology);
- install a new sealing ring DIN 7603-A 5x7,5x1,5-Si into the connection of the lock and release device centrally and without bending. Screw in verified pressure gauge WIKA PGS11.063. Screw up thread connection tightly with the help of torque-measuring open end wrench with attachment (S=14), keeping the connection of the lock and release device with the help of a wrench (S=14) from rotation. Tightening torque 20-22 Nm;
- perform replacement of pressure gauge during two-three minutes in order to avoid risk of clean agent leakage. After pressure gauge installation check for tightness by means of soap test or with the help of a leak detector;
- install protective collar **11 (drawing 2 b)**;
- install the unit into the fixture;
- connect contacts of an electric contact pressure gauge and a solenoid valve;
- connect the unit to electric power supply;
- **before the unit positioning into alert mode, remove a "safety screw" 10 and install a sprayer 8 (drawing 2).**

Enter information on verification (replacement) of an electric contact pressure gauge into the Table B1 (attachment B).

Regulation No. 4. Five years from the date of manufacture of the unit container (see section 13.4) and then every five years:

- remove a sprayer 8 from the unit lock and release device and install a "safety screw" 10 in its place (drawing 2);
- perform preparatory works (see above);

- carry out the unit discharge and technical expert examination of the unit container (hydro-testing by test pressure), inspection of the lock and release device at the nearest service centre of the manufacturer or a representative certified by the manufacturer.

Enter the results of the expert examination into the Table E. 1 (attachment E)

In case of technical expert examination carrying out not at the manufacturer's place or a place of a representative certified by it, lifetime guarantee term is reduced to five years from the date of Clean agent fire suppression system units manufacture.

In case of positive decision based on the results of technical expert examination, the unit is filled with clean agent and nitrogen once more and is installed at the object; in case of negative decision the unit operation is prohibited, it is subject to disposal in accordance with section 10.

8.2 Actions after the unit activation:

- **record about the unit activation in the attachment D;**
- make sure of absence of pressure in the unit by electric contact pressure gauge;
- switch off electric power supply of the unit;
- **remove a sprayer 8 and install a "safety screw" 10 (drawing 2);**
- disconnect the electric circuit of an electric contact pressure gauge and a solenoid valve;
- remove the unit from the fixture (press down locking ball **3 (drawing 7)** and rotating the unit by 90 degrees, withdraw it from a bracket groove);
- send the unit to the nearest service centre of the manufacturer for recovery operations carrying out.

8.3 The list of parts to be replaced after the unit activation:

- rings 003-005-14, 009-012-19, 022-026-25, 027-031-25, 33-036-19 (2 pcs.), 038-041-19 according to GOST 9833-73;
- sealing ring DIN 7603-A 5x7,5x1,5-Si.

At possible repairs of the unit it is necessary to enhance fire watch over the object.

All works on maintenance or repair of the unit, which require interference into design integrity, should be carried out at the manufacturing enterprise, or by the personnel who undergone training and have a relevant certificate to operate the units.

"Innovative Fire Safety Systems", LLC being "ZARYA" units manufacturer, provides training of specialists on units maintenance free of charge with a certificate issuance.

9 TRANSPORTATION AND STORAGE

9.1

Transportation of the unit can be carried out by all types of transport, in covered vehicles, containers, heated pressurized compartments of aircraft in accordance with the rules for carriage of dangerous goods of subclass 2.1 according to GOST 19433-88 applied to the transport of this type.

9.2

Transportation of the unit is carried out at air temperature from - 10 ° C to + 50° C. The unit storage conditions are ZhZ according to GOST 15150-69 (enclosed spaces with natural ventilation) with allowable air temperature from - 10 ° C to + 50° C.

9.3

The unit way of location in vehicles must exclude its movement, falling and collision

9.4

During transportation on open vehicles the unit must be protected from atmospheric precipitations and direct sunlight exposure, heating above 50°C and impacts on it.

9.5

The unit transportation together with gasoline, kerosene, alkali and other substances affecting metal, protective-decorative and lacquer coating, rubber and packing materials is not allowed.

9.6

During loading, transportation and unloading safety precautions must be taken in accordance with marking and inscriptions on packaging.

9.7

Transport and store the unit only with a "safety screw" 10 (drawing 2 b) installed on the lock and release device. It is allowed to transport the unit only in individual package.

9.8

Store the unit at a distance of minimum 1 meter from heaters and at least 5 meters from heat sources with direct flame, exclude direct exposure to sunlight, corrosion-active substances.

9.9

It is prohibited to store units in basements, corridors, passages.

9.10

The unit must be stored in package in an upright position. Stacking - maximum two layers along the height.

10 DISPOSAL

10.1

A unit not undergone a technical expert examination procedure, or with expired service life, is prohibited for operation and must be sent for disposal according to order of facility supervisor.

IT IS PROHIBITED: TO DISASSEMBLE OR DUMP DAMAGED UNIT!

10.2

For the unit disposal it is necessary to:

- remove the unit from maintenance object;
- send to the unit's manufacturer or to the specialized organization, carrying-out acceptance, regeneration and disposal of clean agents for discharge (removal) of clean agent from the unit into a special container with further clean agent transfer to the gas manufacturer;
- check clean agent absence in the unit - by pressure indicator and weighing. Weight of empty unit mustn't exceed the value of its structural mass, specified in the data sheet (see section 11);
- take empty unit to pieces;
- send parts depending on material grade to suitable recyclable materials receiving centers.

10.3

Disposal of fire extinguishing agents is carried out in compliance with the safety and environment protection requirements specified in the technical specifications for this agent.

- Inert gases and their mixtures (nitrogen), which are safe for the environment, after their service life or storage finishing are disposed by means of gas discharge into the atmosphere;
- Ozone-safe fire-extinguishing gases (HFC 227ea, FK-5-1-12), are high-value products and are not subject to disposal. Indicated clean agents after their service life or storage finishing are sent to the gas manufacturer for regeneration. Regenerated gas is reused in gas fire-fighting units. Container with remainder of the product is sent to clean agent supplier.

11 TEST CERTIFICATE

Gas fire-fighting unit

ZARYA- (16- - 18) with a solenoid valve TS 4854-001-62437227-2015

Serial number _____

Empty unit weight
(without clean agent, fixtures, with a "safety screw"), kg _____

Clean agent designation _____

Clean agent weight, kg _____

Unit weight with clean agent and propellant gas
(without fixtures and a "safety screw") _____

Date of unit filling _____

Pressure in the unit container at $20 \pm 2^\circ\text{C}$, MPa _____

Information about pressure gauge:

serial number _____

verification date _____

A gas fire-fighting unit corresponds to technical specifications TS 4854-001-62437227-2015 and is classified as fit for service.

Production date " _____ " 20.

Seal here

signature of QCD representative

ZARYA

12 Warranty liabilities.

LIFETIME GUARANTEE

12.1

The Manufacturer guarantees the unit uninterrupted work if the user meets the rules for operation, transportation and storage specified in the present data sheet.

12.2

Lifetime guarantee is valid during all service life of gas fire-fighting unit and is defined as a period of 10 years from the date of manufacture (production date specified in the data sheet).

12.3

The Manufacturer is obliged to repair the unit free of charge during the warranty period, subject to the compliance with the requirements of sections 6, 7, 8, 9, 12.

12.4

The Manufacturer doesn't accept claims in case of:

- visible mechanical damages;
- if the guarantee service life has expired;
- data sheet for the unit absence;
- dismantling and (or) repair of Clean agent fire suppression system units, carrying out of other actions causing integrity damage of clean agent fire suppression system units by the Buyer or the third parties;
- not meeting the requirements of sections 6, 7, 8, 9, 12.

12.5

The Manufacturer can make alterations in the design of the unit saving its basic operational parameters.

If you have any questions concerning units delivery and quality of manufacture, you should contact the firm-manufacturer:

"ISP", LLC

office A317, bldg. A, unit 2.1, 161 Yuzhnoye Shosse, Togliatti,
Samara Region 445043 tel. 8 (800) 500-30-26

ZARYA

13 INFORMATION ABOUT THE CONTAINER

13.1 General information

The container consists of a leakproof shell welded from two stamp-welded heads 1, a pad for installation at the object, welded on to the top head, and a connection with internal thread M30x1,5, welded on to the opening in the bottom head for installation of the lock and release device of the fire-fighting unit (**drawing 8**). The container outer surface is covered with powder coating, nanocoating can be applied to the container internal surface for service life extension (additional option).

Serial number is marked on the container pad.

The container is intended for storage and transportation of gas fire extinguishing agent HFC 125, HFC 227 ea and FK-5-1-12.

The container is used as part of "ZARYA" gas fire-fighting unit.

Steel container conforms to TS 3695-002-62437227-2015, Technical Regulations of the Customs Union "On safety of equipment operating under excessive pressure" (Declaration of conformity EAEU No. RU D-RU.NV06.V.00017/19 dated 27.12.2019).

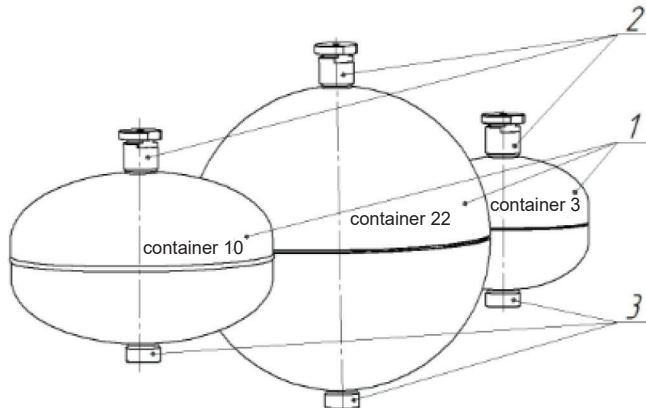

1 - high-pressure container; 2 - pad; 3 - connection
Drawing 8 - Container overview

It is prohibited to operate the container with non-legible marking, expired term of expert examination, with thread damage, cracks, dents, corrosion and nicks on the outer surface.

Table 3 - Container technical characteristics

Parameter name		Container name		
		Container 3	Container 10	Container 22
Container capacity, l		3±0,15	10±0,5	22,5±1,1
Operating pressure, MPa (kgf/cm ²)		3,5 (35)		
Test pressure, MPa (kgf/cm ²)		5,5 (55)		
Overall dimensions, mm, maximum	diameter	210	310	360
	height	225	271	425
Weight, kg, maximum		3.6	6.8	10.0
Specified run (maximum filling number), times		10		
Service life from the date of manufacture, years	without nanocoating	10		
	with nanocoating*	30		
Service life until a successive expert examination is, years	without nanocoating	5		
	with nanocoating *	5		

* - additional option

13.2 Storage and transportation

Container storage is in accordance with ZhZ group of storage conditions, GOST 15150-69. The container must be stored in enclosed, dry, ventilated space on racks. The container transportation is carried out in packs by all types of transport, in covered vehicles at temperature from - 10 to + 50°C.

13.3 Technical expert examination of the container

Technical expert examination of the container is carried out at the nearest service centre of the manufacturer or by specialized organizations authorized for carrying out of technical expert examination of the equipment operating under excessive pressure.

Enter the results of the technical expert examination and date of a subsequent expert examination into the **Table E. 1 (attachment E)**.

A container not undergone a successive technical expert examination, is prohibited for application!

13.4 Container test certificate

Container - TS 3695-002-62437227-2015

Serial number _____

The container protection with the help of nanocoating _____

Empty container weight, kg _____

Container capacity, l _____

Data on containers hydraulic testing:

Test pressure, MPa 5.5

Test medium is water.

Duration of holding 30 minutes

Date of container manufacture _____

Date of a subsequent expert examination _____

Steel container conforms to the requirements of Technical Regulations of the Customs Union "On safety of equipment operating under excessive pressure" (TR CU 032/2013), GOST 34347-2017, TS 3695-002-62437227-2015 and is classified as fit for service.

Production date " _____ " 20.

Seal here

signature of QCD representative

ATTACHMENT B
(obligatory)

Complex of taken measures

Table B.1

Types of work									
Inspection of the lock and release device									
The unit filling:									
Clean agent type									
Clean agent weight, kg									
Unit weight with clean agent, kg (without fixtures, with a "safety screw")									
Date of refilling									
Pressure in the unit, MPa									
Date of an electric contact pressure gauge W/KA verification									
Date of solenoid valve replacement									
Executing organization									
Representative of Executing organization (Full name, signature)	Seal here	Seal here	Seal here	Seal here	Seal here	Seal here	Seal here	Seal here	Seal here

ATTACHMENT C
(referential)

Temperature-pressure dependency diagram

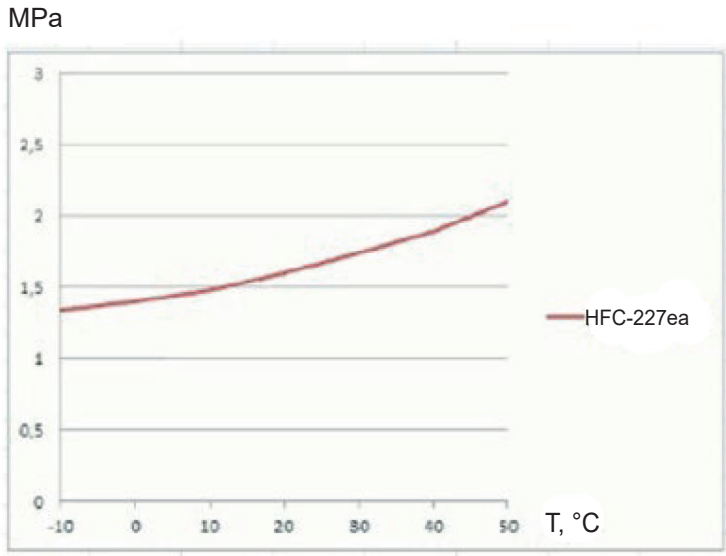

ATTACHMENT D
(obligatory)

Data on the unit activation

Date of the unit activation	Signature, stamp

ATTACHMENT E

(obligatory)

Data on technical expert examination

Table E.1

Date of expert examination	Executing organization	License number for the right of expert examination	Test pressure value, MPa	Date of a subsequent expert examination	Signature, stamp



"Innovative Fire Safety Systems", LLC

8 800 500-30-26
zarya.one